



Since 1971

Low Pressure Gauge SS Crimped Case

P-1D

- Range from 6 inH₂O to 15 PSI including Vacuum and Compound Range
- Excellent Corrosion Resistance Stainless Steel Case
- Capsule Actuated System
- Front Flange for Flushing Panel Mounting Available
- For use with gases

62B
Series

HAWK 62B series capsule system pressure gauges are designed to measure low pressure from 6 inH₂O to 15 PSI.

These gauges use a diaphragm capsule as its sensing element. The sensing element consists two half capsules which are soldered together. The diaphragm capsule element expands by subjecting to pressure. The expansion is converted into the rotary motion of the pointer by a movement. This motion makes users read the scale easily. The wetted parts can be in beryllium copper, brass or 316 stainless steel. All stainless steel low pressure gauges are ideal for use in corrosive and aggressive gas. The stainless steel case is excellent withstanding rugged environment.



Typical Application

- Everywhere low pressure and vacuum measurement is required
- Medical and pharmaceutical industry
- Industrial OEM equipment
- Burner and gas combustion service
- Heating Ventilating
- Air conditioning filtration

Specifications

Operating

Steady: 100%*full scale value

Sudden: 130%*full scale value

All HAWK capsule low pressure gauge are with over-range protection up to 1.3 times of full scale value. Special design for high over-pressure (5 times) protection on request. HAWK Supplies a wide selection of range from 6 inH₂O to 15 PSI including vacuum and compound range.

Temperature limit

Ambient: -20 to 60°C

Winder range request, please consult the factory.

Media: max 60°C-Copper, 100°C-SS

Winder range request, please consult the factory.

Temperature effect

Accuracy of measurement will be affected by the temperature change. This inaccuracy may as high as $\pm 0.3\%$ for 10°C temperature change.

Dial Size

2 1/2" (63mm), 3"(75mm),
4"(100mm).

Case&Ring

Stainless Steel 304 (SS316-option)
crimped ring.

Socket

Brass or 316 Stainless Steel.

Movement

Stainless steel or Brass movement with overload and underload stops-standard.

Capsule Element

Beryllium Copper or Bronze, 316
Stainless Steel.

Window

Polycarbonate.

Pointer

Anodized aluminum with black
finish.

Accuracy

$\pm 2-1-2\%$ of span (1%-option),
(Grade A to ASME B40.1)

Zero-Adjustment

Adjustable screw on dial.

Scale

PSI, kPa, mmH₂O, mbar,
inH₂O, oz./in² (single or dual
scale).

Connection

1/2", 3/8", 1/4", 1/8" NPT
standard, JIS, DIN, M14*1.0,
M20*1.5 available.

Mounting

Stem, Panel (U-clamp)
mounting, Panel flushing
mounting.

Weatherproof

NEMA 3/3X(IP54) enclosure
NEMA 4/4X(IP65)-option.



HAWK

Since 1971

Low Pressure Gauge SS Crimped Case

P-1D

Dimensions

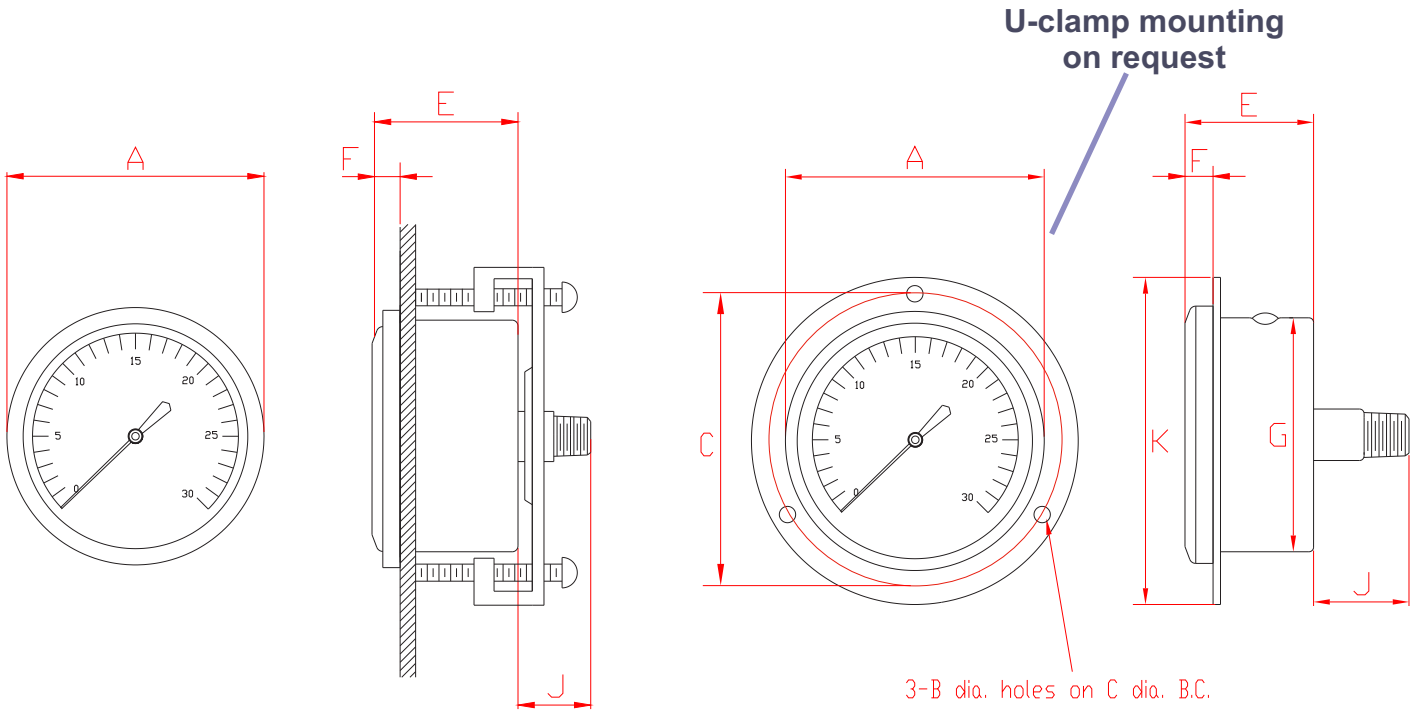

U-clamp

Front Flange

Dimensions, in.(mm)

Type No	Dial Size	A	B	C	D	E	F	G	I	J	K	L	Weight
62B	2.5"	2.68" (68)	0.16" (4)	2.67" (80)		0.35" (8)	1.50" (38)	2.56" (65)		0.91" (23)	3.46" (88)		0.34-0.40 Kg

Type No	Dial Size	A	B	C	D	E	F	G	I	J	K	L	Weight
62B	3"	3.43" (87)	0.20" (5)	3.64" (92.5)		0.32" (8)	1.34" (34)	3.15" (80)		0.91" (23)	4.13" (105)		0.40-0.48 Kg

Type No	Dial Size	A	B	C	D	E	F	G	I	J	K	L	Weight
62B	4"	4.21" (107)	0.20" (5)	4.73" (120)		0.32" (8)	1.34" (34)	3.94" (100)		0.91" (23)	5.12" (130)		0.60-0.60 Kg



HAWK

Since 1971

Low Pressure Gauge SS Crimped Case

P-1D

Pressure Range

■ The other scales and ranges (DIN) are available in request.

■ Not all listed ranges and scales are in stock, consult your distributors for available.

VACUUM RANGES

Mbar

BVH	-16	BVT	-300
BVJ	-25	BVU	-400
BVL	-40	BVV	-500
BVO	-100	BVW	-600
BVR	-200	BVX	-1000

Kpa

KVE	-1.6	KVN	-10
KVG	-2.5	KVP	-20
KVJ	-4	KVT	-40
KVK	-5	KVV	-60
KVL	-6	KVX	-100

mmH2O

HVE	-160
HVF	-200
HVJ	-400
HVM	-600
HVO	-1000
HVR	-2000
HVV	-4000
HVW	-5000
HVX	-6000
HVZ	-10000

inH2O

JVE	-10
JVF	-15
JVG	-20
JVI	-30
JVM	-60
JVO	-100
JVP	-150
JVQ	-200

Code Range

PRESSURE RANGES

PSI

P25	3
P28	5
P31	10
P32	15

Mbar

B20	16	B32	200
B23	20	B33	250
B26	40	B35	400
B28	60	B37	600
B30	100	B39	1000

kPa

K14	1.6	K23	10
K16	2.5	K25	20
K19	4	K29	40
K20	5	K31	60
K21	6	K33	100

mmH2O

H14	160	H26	2000
H15	200	H27	2500
H19	400	H30	4000
H21	600	H32	6000
H23	1000	H34	10000

inH2O

J14	10	J24	100
J15	15	J25A	160
J16	20	J26	200
J19	30		
J22	60		

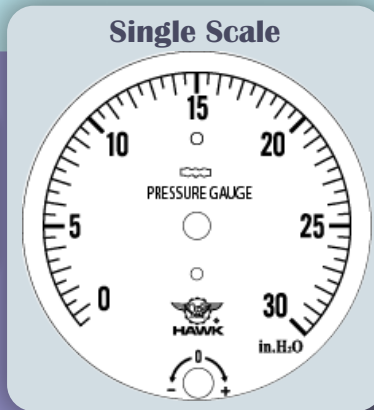

COMPOUND RANGES

Mbar

BCQ	-6/10
BCS	-10/10
BCW	-20/20
BOA	-30/30
BOC	-50/50
BOE	-80/80
BOF	-100/100
BOJ	-200/200
BOM	-300/300
BOP	-500/500

Kpa

KCQ	-1.25/1.25
KCR	-1.5/1.5
KCU	-2/2
KOB	-5/5
KOD	-8/8
KOI	-16/25
KOK	-20/20
KOM	-25/40
KON	-30/30
KOP	-50/50

mmH2O

HCN	-60/100
HCP	-100/100
HCT	-200/200
HCV	-250/400
HCY	-500/500
HOA	-800/800
HOB	-1000/1000
HOF	-2000/2000
HOI	-3000/3000
HOJ	-5000/5000

inH2O

JCL	-5/5
JCM	-10/10
JCN	-15/15
JCO	-20/20
JCP	-30/30
JCQ	-50/50
JCQA	-60/60
JCR	-100/100
JCS	-150/150
JCT	-200/200

Code Range

PRESSURE RANGES

mbar & mmH2O

Q22	16	Q32	200
Q23	20	Q33	250
Q26	40	Q35	400
Q28	60	Q37	600
Q30	100	Q39	1000

oz./in2. & inH2O

F27	6	F301	35
F271	9	F31	60
F28	12	F32	100
F29	20	F33	160
F30	30	F34	250

VACUUM RANGES

mbar & mmH2O

QVH	-16	QVR	-200
QVI	-20	QVS	-250
QVL	-40	QVU	-400
QVN	-60	QVW	-600
QVO	-100	QVX	-1000

oz./in2. & inH2O

FVR	-6	FVU1	-35
FVR1	-9	FVV	-60
FVS	-12	FVW	-100
FVT	-20	FVX	-160
FVU	-30	FVY	-250

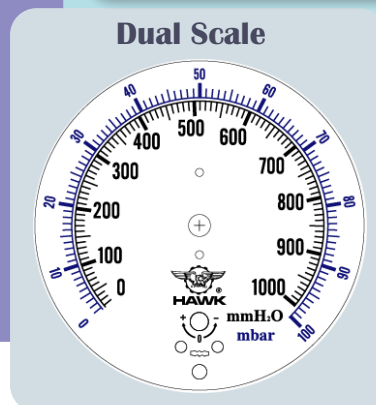

COMPOUND RANGES

mbar & mmH2O

QCP	-5/5	QOG	-100/100
QCS	-10/10	QOI	-125/125
QCU	-12.5/12.5	QOK	-200/200
QCW	-20/20	QON	-300/300
QOD	-50/50	QOQ	-500/500



HAWK

Since 1971

Low Pressure Gauge SS Crimped Case

P-1D

Order Information

Example:

Series	Model	Dial	Wetted Parts	Process Connection	Pressure Range	Option	
P-1D-62	B	25	S	M 2	Q 3 0	H- Z U	
	B-Lower Back Connection	25-2 1/2" (63mm) 03-3" (75mm) 04-4" (100mm)	S-316SS B-Brass	M-Male F-Female 0L-Others	2-1/2"NPT 4-1/4"NPT 3-3/8"NPT D-G1/2 H-G3/8 E-G1/4 A-R1/2 G-R3/8 B-R1/4	Please refer to the range table and write down the code you need. Vacuum Compound Pressure	ZU-U-clamp Other options please check the next page

Option

ZC Certificate of Accuracy (Factory)

ZE Certificate of Accuracy (TAF)

ZI Certificate of Accuracy (NIST)

ZN NACE-MR0175-2002 Heat Treatment

ZX Cleaned for Oxygen Service (Use No Oil)

ZV Rubber Cover

ZY Stainless Steel Tag Plate

ZU Stainless Steel U-Clamp Bracket

OM Stop Pin at 6 O'clock

OP Stop Pin



Low Pressure Gauge SS Crimped Case

P-1D

Limited Warranty and Liability

HAWK GAUGE CO.,LTD warrants all its mechanical instruments to be free from defects in materials and workmanship. HAWK agrees to repair or replace any pressure gauges if returned to our factory, transportation charges prepaid, and after which examination reveals is to be defective due to faculty workmanship or material.

This warrant should not apply to subject to the following terms and conditions:

- A. The product has not been subjected to misuse, neglect, abuse , accident, incorrect mounting, improper use or misapplication such as negligence, accident, vandalism, shock or vibration.
- B. The performance of any system of which HAWK's products are a component part.
- C. The product has not been exposed to any other service, range or environment of greater severity than that for which the products were designed.
- D. The product has not been altered or repaired by anyone except HAWK GAUGE or its authorized service agencies.
- E. The serial number or date code has not been removed, defaced or changed.
- F. The actual pressure&temperature occurring exceed the values specified for HAWK Process gauge.

Unless otherwise specified in a manual or warranty card, or agree to in a writing signed by HAWK GAUGE office, HAWK Process gauge products shall be warranted for one years from the date of sale.

This warranty is in lieu of all other warranties expressed or implied, and of all obligations or liabilities on its part for damages including but not limited to consequential damages, following the use of misuse of instruments sold by it.

No agent is authorized to assume for it any liability except as set forth above.

Note

HAWK GAUGE CO.,LTD reserves the right to make product improvements and change its specifications at any time stated throughout this brochure without notification. Please contact the factory on all critical dimensions and specifications for verification.

HAWK GAUGE is not expert in the customer's technical field and therefore doesn't warrant suitability of it's product for the application selected by customer.



Data Sheet No: MKDP1D62A3-E